

50KW Natural Gas Generator

Cummins Engine | 60 Hz | 1800 RPM



Genset Specifications	
Model	WDG-50-CUM-NAT
Power	50 kW 62 kVA
Frequency	60 Hz
Speed	1800 RPM
Standard Voltage	120/240V 1PH 277/480V 3PH
Overall Dimensions (L x W x H)	98.4 x 37.4 x 56.3 (in.)
Net Weight (lbs.)	3,300

Engine Data	
Model	Cummins 6BT5.9-G2
Type	Water-cooled, 6 cylinder, in-line, 4 strokes
Engine Speed	1800 RPM
Governor Type	Electronic
Air Intake Method	Turbocharged & Intercooled (air to air)
Displacement (L)	5.9 L
Bore x Stroke (in.)	4.02 x 4.72 in.
Compression Ratio	17.3:1
Coolant Capacity (Engine only)	2.09 gal.

Alternator Data	
Model	UCI224E 1PH UCI224D 3PH
Rating	50 KW
Excitation Mode	Self-exciting
Voltage Control Mode	AVR automatically regulates pressure
Phase Number Connection Method	Three-phase, Four-wire
Type	Synchronous, brushless
Insulation Class	H
Protection Level	IP23
Cooling Method	Air cooling
Harmonic Distortion (THD)	< 3.5%
Frequency Adjustment Rate (%)	± 0.5 (steady state) +10 ~ -7 (transient state)
Transient Voltage Adjustment Rate (%)	± 0.5 (steady state) +20 ~ -15 (transient state)

50KW Natural Gas Generator

Cummins Engine | 60 Hz | 1800 RPM

Fuel Type: Natural Gas	
Lower Heating Value (LHV)	950-1050 btu/scft
Methane Number (MN)	Nominal 75 (range 70 to 80)
Specification	IC-G-D-30-021

Fuel Type: Non Commercial Gas (Well Gas)	
Lower Heating Value (LHV)	800-1600 btu/scft
Methane Number (MN)	Nominal > 45
Recommended Specification	IC-G-D-30-139

Fuel Type: LPG-Propane (>85% C3H8)	
Lower Heating Value (LHV)	2400-2680 btu/scft
Methane Number (MN)	N/A
Recommended Specification	HD5 Propane IC-G-D-30-138

Gas Train	
Fuel Pressure Range	2 to 7 PSI
Fuel Control	Madas Regulator Gas Inlet + Venturi Valve Gas Carburetor
Connection	ANSI flanged

Fuel Consumption Nm ³ /h 60Hz	
	Natural Gas
100% Load	17
75% Load	13
50% Load	8
25% Load	5.5

CUMMINS ENGINE DATASHEET



ENGINE MODEL: 6BTA5.9-G2

PERFORMANCE CURVE: FR 92306



DONGFENG CUMMINS ENGINE Co., Ltd.
XiangFan HubBei P.R.CHINA
ENGINE DATASHEET—for G-drive

ENGINE MODEL 6BTA5.9-G2	PERFORMANCE CURVE FR 92306
ENGINE FAMILY D40	CPL 2697
2006/11	

Displacement	5.9 L	Air intake way	After-cooled, turbo-charged
Cylinder bore	102 mm	Cylinder quantity	6
Stroke	120 mm		
Fuel system	PB pump _ GAC governor / BYC ASIMCO		

Engine testing with fuel system, water pump and oil pump, without air compressor, alternator, fan, other options and driving accessory.
 Testing condition : air intake resistance 250 mmHg, exhaust back pressure 50 mmHg.

Engine Speed-RPM	Standby Power		Base Output Power		Continuous Power	
	KW	HP	KW	HP	KW	HP
1500	116	155	106	142	56	75

Output Power %	Fuel consumption		
	KW	HP	L/h
100	116	155	212
Base Output Power			
100	106	142	211
75	80	107	212
50	53	71	219
25	27	36	248
Continuous Power			
100	56	75	218

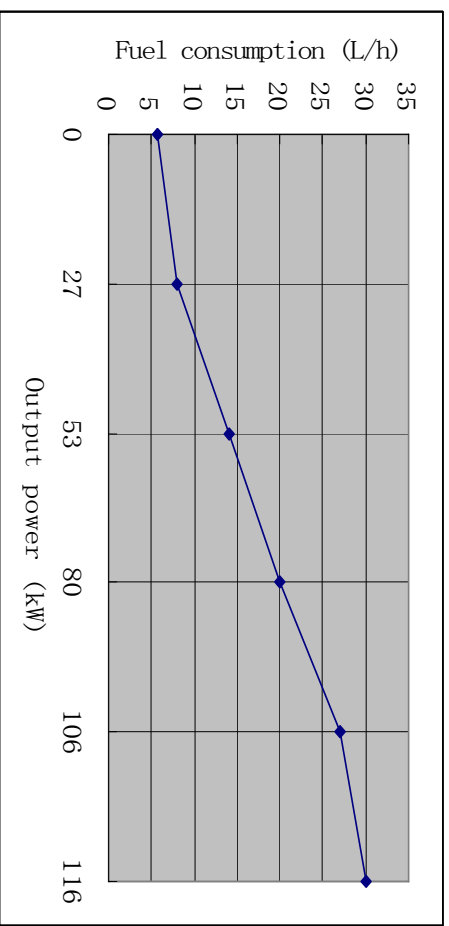



DONGFENG CUMMINS ENGINE Co., Ltd.
XiangFan Hubei P.R.CHINA
ENGINE DATASHEET—for G-drive

ENGINE MODEL	PERFORMANCE CURVE
6BTA5.9-G2	FR 92306
ENGINE FAMILY	
D40	2006/11
CPL	
2697	

Typical engine data

Net weight

kg

453

Rotate part instantaneous inertia _ without flywheel

kg.m²

0.25

Distance between gravity center and rear surface of cylinder block

mm

391

Distance between gravity center and center line above of crankshaft

mm

140

Engine installation

Static bent torque permitted—rear surface of cylinder block

N.m

1356

Static bent torque permitted—front surface of cylinder block

N.m

435

Static bent torque permitted—flank surface of cylinder block

N.m

365

Exhaust system

Max. back pressure

mmHg

76

Diameter of exhaust pipe recommended

mm

75

Air intake system

Max. air intake resistance

mmH₂O

635

Dirty filter

mmH₂O

254

Normal air cleaner and clean filter

mmH₂O

381

Heavy duty cleaner and clean filter

mm

100

Diameter of intake pipe recommended

mm

100

Lubrication system

Normal oil pressure range

Low idle
 Rated speed
 Max. oil temperature permitted in oil pan
 Oil pan capacity (Max _ Min)
 Lubrication system Min. capacity (oil pan + oil filter)
 Usage inclining degree permitted (any direction)

KPa 207
 KPa 345
 °C 121
 L 14.2_12.3
 L 16:3
 ° 40

Fuel system

Fuel injection pump model
 Max. fuel input resistance of transfer pump
 Max. overflow fuel resistance at overflow pipe of injector
 Total fuel overflow amount

PB pump _ GAC governor / BYC ASIMCO

mmHg 102
 mmHg 508
 L/h 30

Cooling system

Coolant capacity-engine only
 Max. coolant cycling resistance exterior engine
 Thermostat adjusting temperature (range)
 Min. opening pressure of radiator cap
 Max. coolant temperature permitted _ Standby Power/Base output Power

L 10
 KPa 28
 °C 82_95
 KPa 69
 °C 104/100

Electric system

Starter
 Battery charging system
 Max. starting circuit resistance
 Min. battery capacity _ -12°C (CCA: Cold Cranking Ampere)

12V 24V
 63A 40A
 0.00075Ω 0.002Ω
 800CCA 400CCA

Technical data _ under standard fuel delivery rate FR 92306
 Engine speed _ RPM
 Output Power _ kW

Base output Power **Standby Power**
 1500 1500
 106 116

Torque _ Nm
Low idle _ RPM
Friction energy output _ kW
Piston speed _ m/s
Engine coolant flow _ L/sec
Air intake flow _ L/sec
Exhaust flow _ L/sec
Exhaust temperature _ °C
Environment energy output _ kW
Coolant energy output _ kW
Fuel energy output _ kW

	675	739
	750-850	750-850
	12.7	12.7
	6.0	6.0
	2.0	2.0
	N/A	N/A
	N/A	N/A
	540	570
	N/A	N/A
	63	67.5
	N/A	N/A

All data's error within ±5%.

Excuse for none notice anymore in case of data changed

DONGFENG CUMMINS ENGINE Co., Ltd.

STAMFORD®

UCI224D - Winding 311

Technical  Data Sheet

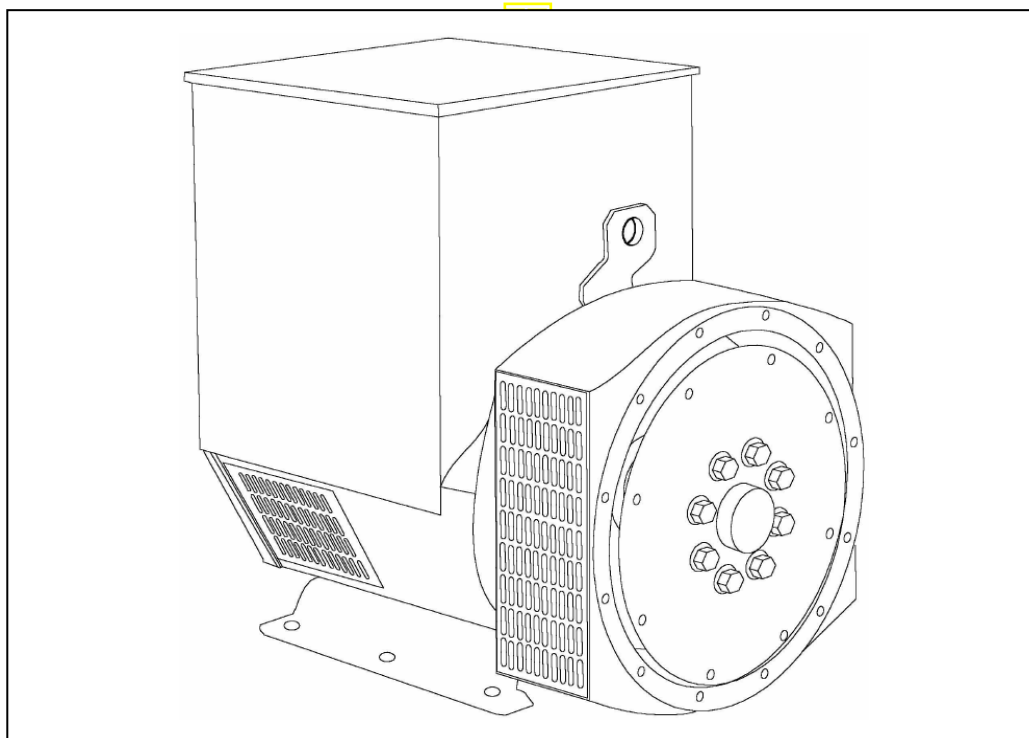

SPECIFICATIONS & OPTIONS

STANDARDS

Stamford industrial generators meet the requirements of BS EN 60034 and the relevant section of other international standards such as BS5000, VDE 0530, NEMA MG1-32, IEC34, CSA C22.2-100, AS1359.

Other standards and certifications can be considered on request.

VOLTAGE REGULATORS

SX460 AVR - STANDARD

With this self excited control system the main stator supplies power via the Automatic Voltage Regulator (AVR) to the exciter stator. The high efficiency semiconductors of the AVR ensure positive build-up from initial low levels of residual voltage. The exciter rotor output is fed to the main rotor through a three phase full wave bridge rectifier. This rectifier is protected by a surge suppressor against surges caused, for example, by short circuit.

AS440 AVR

With this self-excited system the main stator provides power via the AVR to the exciter stator. The high efficiency semiconductors of the AVR ensure positive build-up from initial low levels of residual voltage.

The exciter rotor output is fed to the main rotor through a three-phase full-wave bridge rectifier. The rectifier is protected by a surge suppressor against surges caused, for example, by short circuit or out-of-phase paralleling.

The AS440 will support a range of electronic accessories, including a 'droop' Current Transformer (CT) to permit parallel operation with other ac generators.

MX341 AVR

This sophisticated AVR is incorporated into the Stamford Permanent Magnet Generator (PMG) control system.

The PMG provides power via the AVR to the main exciter, giving a source of constant excitation power independent of generator output. The main exciter output is then fed to the main rotor, through a full wave bridge, protected by a surge suppressor. The AVR has in-built protection against sustained over-excitation, caused by internal or external faults. This de-excites the machine after a minimum of 5 seconds.

An engine relief load acceptance feature can enable full load to be applied to the generator in a single step.

If three-phase sensing is required with the PMG system the MX321 AVR must be used.

We recommend three-phase sensing for applications with greatly unbalanced or highly non-linear loads.

MX321 AVR

The most sophisticated of all our AVRs combines all the features of the MX341 with, additionally, three-phase rms sensing, for improved regulation and performance.

Over voltage protection is built-in and short circuit current level adjustments is an optional facility.

WINDINGS & ELECTRICAL PERFORMANCE

All generator stators are wound to 2/3 pitch. This eliminates triplen (3rd, 9th, 15th ...) harmonics on the voltage waveform and is found to be the optimum design for trouble-free supply of non-linear loads. The 2/3 pitch design avoids excessive neutral currents sometimes seen with higher winding pitches, when in parallel with the mains. A fully connected damper winding reduces oscillations during paralleling. This winding, with the 2/3 pitch and carefully selected pole and tooth designs, ensures very low waveform distortion.

TERMINALS & TERMINAL BOX

Standard generators are 3-phase reconnectable with 12 ends brought out to the terminals, which are mounted on a cover at the non-drive end of the generator. A sheet steel terminal box contains the AVR and provides ample space for the customers' wiring and gland arrangements. It has removable panels for easy access.

SHAFT & KEYS

All generator rotors are dynamically balanced to better than BS6861:Part 1 Grade 2.5 for minimum vibration in operation.

INSULATION/IMPREGNATION

The insulation system is class 'H'.

All wound components are impregnated with materials and processes designed specifically to provide the high build required for static windings and the high mechanical strength required for rotating components.

QUALITY ASSURANCE

Generators are manufactured using production procedures having a quality assurance level to BS EN ISO 9001.

The stated voltage regulation may not be maintained in the presence of certain radio transmitted signals. Any change in performance will fall within the limits of Criteria 'B' of EN 61000-6-2:2001. At no time will the steady-state voltage regulation exceed 2%.

DE RATES

All values tabulated on page 8 are subject to the following reductions

5% when air inlet filters are fitted.

3% for every 500 metres by which the operating altitude exceeds 1000 metres above mean sea level.

3% for every 5°C by which the operational ambient temperature exceeds 40°C.

Note: Requirement for operating in an ambient exceeding 60°C must be referred to the factory.

NB Continuous development of our products entitles us to change specification details without notice, therefore they must not be regarded as binding.

Front cover drawing typical of product range.

UCI224D



WINDING 311

CONTROL SYSTEM	SEPARATELY EXCITED BY P.M.G.		
A.V.R.	MX321	MX341	
VOLTAGE REGULATION	± 0.5 %	± 1.0 %	With 4% ENGINE GOVERNING
SUSTAINED SHORT CIRCUIT	REFER TO SHORT CIRCUIT DECREMENT CURVES (page 7)		

CONTROL SYSTEM	SELF EXCITED		
A.V.R.	SX460	AS440	
VOLTAGE REGULATION	± 1.0 %	± 1.0 %	With 4% ENGINE GOVERNING
SUSTAINED SHORT CIRCUIT	SERIES 4 CONTROL DOES NOT SUSTAIN A SHORT CIRCUIT CURRENT		

INSULATION SYSTEM	CLASS H							
PROTECTION	IP23							
RATED POWER FACTOR	0.8							
STATOR WINDING	DOUBLE LAYER CONCENTRIC							
WINDING PITCH	TWO THIRDS							
WINDING LEADS	12							
STATOR WDG. RESISTANCE	0.129 Ohms PER PHASE AT 22°C SERIES STAR CONNECTED							
ROTOR WDG. RESISTANCE	0.64 Ohms at 22°C							
EXCITER STATOR RESISTANCE	21 Ohms at 22°C							
EXCITER ROTOR RESISTANCE	0.071 Ohms PER PHASE AT 22°C							
R.F.I. SUPPRESSION	BS EN 61000-6-2 & BS EN 61000-6-4, VDE 0875G, VDE 0875N. refer to factory for others							
WAVEFORM DISTORTION	NO LOAD < 1.5% NON-DISTORTING BALANCED LINEAR LOAD < 5.0%							
MAXIMUM OVERSPEED	2250 Rev/Min							
BEARING DRIVE END	BALL. 6312-2RS (ISO)							
BEARING NON-DRIVE END	BALL. 6309-2RS (ISO)							
	1 BEARING				2 BEARING			
WEIGHT COMP. GENERATOR	285 kg				290 kg			
WEIGHT WOUND STATOR	86 kg				86 kg			
WEIGHT WOUND ROTOR	86.28 kg				77.9 kg			
WR ² INERTIA	0.4216 kgm ²				0.4198 kgm ²			
SHIPPING WEIGHTS in a crate	307 kg				311 kg			
PACKING CRATE SIZE	97 x 57 x 96(cm)				97 x 57 x 96(cm)			
	50 Hz				60 Hz			
TELEPHONE INTERFERENCE	THF < 2%				TIF < 50			
COOLING AIR	0.216 m ³ /sec 458 cfm				0.281 m ³ /sec 595 cfm			
VOLTAGE SERIES STAR	380/220	400/231	415/240	440/254	416/240	440/254	460/266	480/277
VOLTAGE PARALLEL STAR	190/110	200/115	208/120	220/127	208/120	220/127	230/133	240/138
VOLTAGE SERIES DELTA	220/110	230/115	240/120	254/127	240/120	254/127	266/133	277/138
KVA BASE RATING FOR REACTANCE VALUES	50	50	50	37.5	60	62.5	62.5	65
X _d DIR. AXIS SYNCHRONOUS	2.33	2.10	1.95	1.30	3.04	2.83	2.59	2.47
X' _d DIR. AXIS TRANSIENT	0.18	0.16	0.15	0.10	0.22	0.20	0.19	0.18
X'' _d DIR. AXIS SUBTRANSIENT	0.12	0.11	0.10	0.07	0.15	0.14	0.13	0.12
X _q QUAD. AXIS REACTANCE	1.07	0.97	0.90	0.60	1.40	1.30	1.19	1.14
X'' _q QUAD. AXIS SUBTRANSIENT	0.14	0.13	0.12	0.08	0.14	0.13	0.12	0.11
X _L LEAKAGE REACTANCE	0.07	0.06	0.06	0.04	0.09	0.08	0.08	0.07
X ₂ NEGATIVE SEQUENCE	0.13	0.12	0.11	0.07	0.14	0.13	0.12	0.11
X ₀ ZERO SEQUENCE	0.08	0.08	0.07	0.05	0.09	0.08	0.08	0.07
REACTANCES ARE SATURATED				VALUES ARE PER UNIT AT RATING AND VOLTAGE INDICATED				
T' _d TRANSIENT TIME CONST.	0.027 s							
T'' _d SUB-TRANSTIME CONST.	0.006 s							
T' _{do} O.C. FIELD TIME CONST.	0.7 s							
T _a ARMATURE TIME CONST.	0.0055 s							
SHORT CIRCUIT RATIO	1/X _d							

UCI224D
Winding 311 / 0.8 Power Factor

RATINGS

Class - Temp Rise		Cont. F - 105/40°C				Cont. H - 125/40°C				Standby - 150/40°C				Standby - 163/27°C			
50 Hz	Series Star (V)	380	400	415	440	380	400	415	440	380	400	415	440	380	400	415	440
	Parallel Star (V)	190	200	208	220	190	200	208	220	190	200	208	220	190	200	208	220
	Series Delta (V)	220	230	240	254	220	230	240	254	220	230	240	254	220	230	240	254
	kVA	45.0	45.0	45.0	33.6	50.0	50.0	50.0	37.5	53.0	53.0	53.0	39.1	55.0	55.0	55.0	41.2
	kW	36.0	36.0	36.0	26.9	40.0	40.0	40.0	30.0	42.4	42.4	42.4	31.3	44.0	44.0	44.0	33.0
	Efficiency (%)	88.3	88.6	88.9	89.7	87.7	88.2	88.5	89.6	87.4	87.9	88.2	89.5	87.2	87.7	88.0	89.4
	kW Input	40.8	40.6	40.5	30.0	45.6	45.4	45.2	33.5	48.5	48.2	48.1	35.0	50.5	50.2	50.0	36.9
60 Hz	Series Star (V)	416	440	460	480	416	440	460	480	416	440	460	480	416	440	460	480
	Parallel Star (V)	208	220	230	240	208	220	230	240	208	220	230	240	208	220	230	240
	Delta (V)	240	254	266	277	240	254	266	277	240	254	266	277	240	254	266	277
	kVA	52.5	55.0	56.0	58.0	60.0	62.5	62.5	65.0	62.5	65.0	65.0	68.8	65.0	66.3	66.3	71.3
	kW	42.0	44.0	44.8	46.4	48.0	50.0	50.0	52.0	50.0	52.0	52.0	55.0	52.0	53.0	53.0	57.0
	Efficiency (%)	88.7	89.0	89.2	89.4	88.0	88.4	88.8	89.0	87.8	88.2	88.6	88.7	87.5	88.1	88.5	88.5
	kW Input	47.4	49.4	50.2	51.9	54.5	56.6	56.3	58.4	56.9	59.0	58.7	62.1	59.4	60.2	59.9	64.5

DIMENSIONS

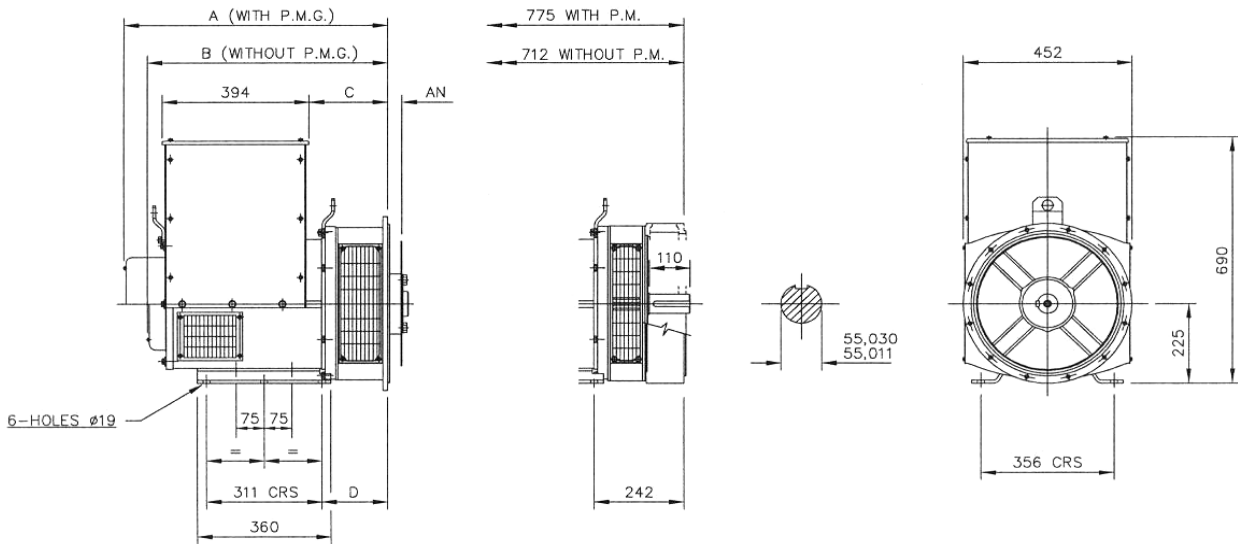

SINGLE BEARING MACHINES ONLY						
ADAPTOR	A	B	C	D	COUPLING DISCS	AN
SAE 1	724,3	661,3	224,3	191,3	SAE 8	61,90
SAE 2	710	647	210	177	SAE 10	53,98
SAE 3	710	647	210	177	SAE 11,5	39,68
SAE 4	710	647	210	177	SAE 14	25,40

STAMFORD[®]

UCI224E - Winding 14

Technical Data Sheet

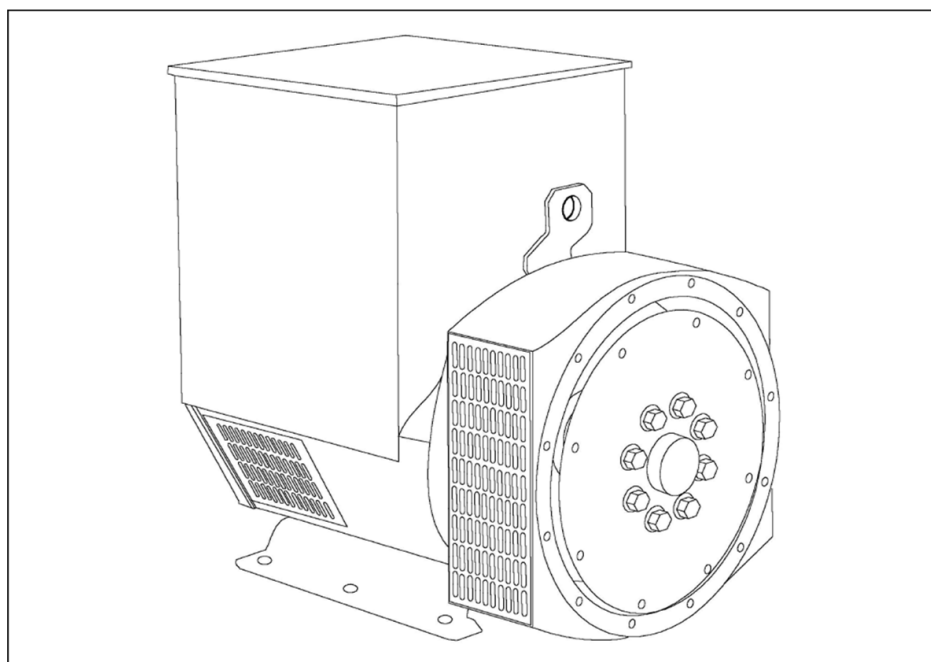

SPECIFICATIONS & OPTIONS

STANDARDS

Stamford industrial generators meet the requirements of BS EN 60034 and the relevant section of other international standards such as BS5000, VDE 0530, NEMA MG1-32, IEC34, CSA C22.2-100, AS1359.

Other standards and certifications can be considered on request.

VOLTAGE REGULATORS**SX460 AVR - OBSOLETE**

With this self excited control system the main stator supplies power via the Automatic Voltage Regulator (AVR) to the exciter stator. The high efficiency semiconductors of the AVR ensure positive build-up from initial low levels of residual voltage.

The exciter rotor output is fed to the main rotor through a three phase full wave bridge rectifier. This rectifier is protected by a surge suppressor against surges caused, for example, by short circuit.

AS440 AVR - STANDARD

With this self-excited system the main stator provides power via the AVR to the exciter stator. The high efficiency semi-conductors of the AVR ensure positive build-up from initial low levels of residual voltage.

The exciter rotor output is fed to the main rotor through a three-phase full-wave bridge rectifier. The rectifier is protected by a surge suppressor against surges caused, for example, by short circuit or out-of-phase paralleling.

The AS440 will support a range of electronic accessories, including a 'droop' Current Transformer (CT) to permit parallel operation with other ac generators.

MX341 AVR

This sophisticated AVR is incorporated into the Stamford Permanent Magnet Generator (PMG) control system.

The PMG provides power via the AVR to the main exciter, giving a source of constant excitation power independent of generator output. The main exciter output is then fed to the main rotor, through a full wave bridge, protected by a surge suppressor. The AVR has in-built protection against sustained over-excitation, caused by internal or external faults. This de-excites the machine after a minimum of 5 seconds.

An engine relief load acceptance feature can enable full load to be applied to the generator in a single step.

If three-phase sensing is required with the PMG system the MX321 AVR must be used.

We recommend three-phase sensing for applications with greatly unbalanced or highly non-linear loads.

MX321 AVR

The most sophisticated of all our AVRs combines all the features of the MX341 with, additionally, three-phase rms sensing, for improved regulation and performance.

Over voltage protection is built-in and short circuit current level adjustments is an optional facility.

WINDINGS & ELECTRICAL PERFORMANCE

All generator stators are wound to 2/3 pitch. This eliminates triplen (3rd, 9th, 15th ...) harmonics on the voltage waveform and is found to be the optimum design for trouble-free supply of non-linear loads. The 2/3 pitch design avoids excessive neutral currents sometimes seen with higher winding pitches, when in parallel with the mains. A fully connected damper winding reduces oscillations during paralleling. This winding, with the 2/3 pitch and carefully selected pole and tooth designs, ensures very low waveform distortion.

TERMINALS & TERMINAL BOX

Standard generators are 3-phase reconnectable with 12 ends brought out to the terminals, which are mounted on a cover at the non-drive end of the generator. A sheet steel terminal box contains the AVR and provides ample space for the customers' wiring and gland arrangements. It has removable panels for easy access.

SHAFT & KEYS

All generator rotors are dynamically balanced to better than BS6861:Part 1 Grade 2.5 for minimum vibration in operation. Two bearing generators are balanced with a half key.

INSULATION/IMPREGNATION

The insulation system is class 'H'.

All wound components are impregnated with materials and processes designed specifically to provide the high build required for static windings and the high mechanical strength required for rotating components.

QUALITY ASSURANCE

Generators are manufactured using production procedures having a quality assurance level to BS EN ISO 9001.

The stated voltage regulation may not be maintained in the presence of certain radio transmitted signals. Any change in performance will fall within the limits of Criteria 'B' of EN 61000-6-2:2001. At no time will the steady-state voltage regulation exceed 2%.

DE RATES

All values tabulated on page 7 are subject to the following reductions

5% when air inlet filters are fitted.

3% for every 500 metres by which the operating altitude exceeds 1000 metres above mean sea level.

3% for every 5°C by which the operational ambient temperature exceeds 40°C.

Note: Requirement for operating in an ambient exceeding 60°C must be referred to the factory.

NB Continuous development of our products entitles us to change specification details without notice, therefore they must not be regarded as binding.

Front cover drawing typical of product range.

UCI224E
WINDING 14

STAMFORD

CONTROL SYSTEM	SEPARATELY EXCITED BY P.M.G.		
A.V.R.	MX341	MX321	
VOLTAGE REGULATION	± 1%	± 0.5 %	With 4% ENGINE GOVERNING
SUSTAINED SHORT CIRCUIT	REFER TO SHORT CIRCUIT DECREMENT CURVES (page 6)		
CONTROL SYSTEM	SELF EXCITED		
A.V.R.	SX460	AS440	
VOLTAGE REGULATION	± 1.0 %	± 1.0 %	With 4% ENGINE GOVERNING
SUSTAINED SHORT CIRCUIT	SERIES 4 CONTROL DOES NOT SUSTAIN A SHORT CIRCUIT CURRENT		
INSULATION SYSTEM	CLASS H		
PROTECTION	IP23		
RATED POWER FACTOR	0.8		
STATOR WINDING	DOUBLE LAYER LAP		
WINDING PITCH	TWO THIRDS		
WINDING LEADS	12		
MAIN STATOR RESISTANCE	0.07 Ohms PER PHASE AT 22°C STAR CONNECTED		
MAIN ROTOR RESISTANCE	0.69 Ohms at 22°C		
EXCITER STATOR RESISTANCE	20 Ohms at 22°C		
EXCITER ROTOR RESISTANCE	0.078 Ohms PER PHASE AT 22°C		
R.F.I. SUPPRESSION	BS EN 61000-6-2 & BS EN 61000-6-4, VDE 0875G, VDE 0875N. refer to factory for others		
WAVEFORM DISTORTION	NO LOAD < 1.5% NON-DISTORTING BALANCED LINEAR LOAD < 5.0%		
MAXIMUM OVERSPEED	2250 Rev/Min		
BEARING DRIVE END	BALL. 6312-2RS (ISO)		
BEARING NON-DRIVE END	BALL. 6309-2RS (ISO)		
	1 BEARING		2 BEARING
WEIGHT COMP. GENERATOR	311 kg		330 kg
WEIGHT WOUND STATOR	103 kg		103 kg
WEIGHT WOUND ROTOR	95.89 kg		87.52 kg
WR ² INERTIA	0.4999 kgm ²		0.4682 kgm ²
SHIPPING WEIGHTS in a crate	334 kg		351 kg
PACKING CRATE SIZE	105 x 57 x 96(cm)		105 x 57 x 96(cm)
TELEPHONE INTERFERENCE	THF<2%		TIF<50
COOLING AIR	0.281 m ³ /sec 595 cfm		
VOLTAGE STAR	380/220	400/230	416/240
kVA BASE RATING FOR REACTANCE VALUES	70	70	70
X _d DIR. AXIS SYNCHRONOUS	2.49	2.25	2.08
X _d DIR. AXIS TRANSIENT	0.19	0.17	0.16
X ["] _d DIR. AXIS SUBTRANSIENT	0.13	0.11	0.10
X _q QUAD. AXIS REACTANCE	1.15	1.04	0.96
X ["] _q QUAD. AXIS SUBTRANSIENT	0.12	0.11	0.10
X _L LEAKAGE REACTANCE	0.07	0.06	0.06
X ₂ NEGATIVE SEQUENCE	0.12	0.11	0.10
X ₀ ZERO SEQUENCE	0.07	0.06	0.06
REACTANCES ARE SATURATED VALUES ARE PER UNIT AT RATING AND VOLTAGE INDICATED			
T _d TRANSIENT TIME CONST.	0.028s		
T ["] _d SUB-TRANSTIME CONST.	0.007s		
T ["] _{do} O.C. FIELD TIME CONST.	0.7s		
T _a ARMATURE TIME CONST.	0.006s		
SHORT CIRCUIT RATIO	1/X _d		

UCI224E**STAMFORD****Winding 14 / 0.8 Power Factor****60Hz****RATINGS**

Class - Temp Rise	Cont. F - 105/40°C			Cont. H - 125/40°C			Standby - 150/40°C			Standby - 163/27°C		
Series Star (V)	380	400	416	380	400	416	380	400	416	380	400	416
Parallel StarStar (V)	190	200	208	190	200	208	190	200	208	190	200	208
Series Delta (V)	220	230	240	220	230	240	220	230	240	220	230	240
kVA	65.0	65.0	65.0	70.0	70.0	70.0	73.8	73.8	73.8	75.0	75.0	75.0
kW	52.0	52.0	52.0	56.0	56.0	56.0	59.0	59.0	59.0	60.0	60.0	60.0
Efficiency (%)	89.8	90.1	90.4	89.5	89.9	90.1	89.3	89.7	90.0	89.2	89.6	89.9
kW Input	57.9	57.7	57.6	62.6	62.3	62.1	66.1	65.8	65.6	67.3	67.0	66.7

Dimensional and Torsional Drawing

For dimensional and torsional information please refer to the alternator General Arrangement and rotor drawings available on our website (<http://stamford-avk.com/>)

DSE7310/20 MKII

AUTO START & AUTO MAINS FAILURE CONTROL MODULES



KEY FEATURES

- Configurable power-up mode
- MPU fail delay
- Enhanced graphical user interface
- Drag & drop advanced PLC editor
- MSC ID within PLC GenComm override
- 4-Line back-lit LCD text display
- Multiple Display Languages
- Five key menu navigation
- LCD alarm indication
- Heated display option available
- Customisable power-up text and images
- DSENet expansion compatibility
- Data logging facility
- Internal PLC editor
- Protections disable feature
- Fully configurable via PC using USB, RS232 & RS485 communication
- Front panel configuration with PIN protection
- Power save mode
- 3 phase generator sensing and protection
- 3 phase mains (utility) sensing and protection (DSE7320 MKII only)
- Automatic load transfer control (DSE7320 MKII only)
- Generator current and power monitoring (kW, kvar, kVA, pf)
- Mains current and power monitoring (kW, kvar, kVA, pf) (DSE7320 MKII only)
- kW and kvar overload and reverse power alarms
- Over current protection
- Unbalanced load protection
- Independent earth fault protection
- Breaker control via fascia buttons
- Fuel and start outputs configurable when using CAN
- 6 configurable DC outputs
- 2 configurable volt-free relay outputs
- 6 configurable analogue/digital inputs
- Support for 0 V to 10 V & 4 mA to 20 mA sensors
- 8 configurable digital inputs
- Configurable 5 stage dummy load and load shedding outputs
- CAN, MPU and alternator frequency speed sensing in one variant
- Real time clock
- Manual and automatic fuel pump control
- Engine pre-heat and post-heat functions
- Engine run-time scheduler
- Engine idle control for starting & stopping
- Fuel usage monitor and low fuel level alarms
- Simultaneous use of RS232 and RS485 communication ports
- True dual mutual standby using RS232 or RS485 for accurate engine hours balancing.
- MODBUS RTU support with configurable MODBUS pages.
- Advanced SMS messaging (additional external modem required)
- Start & stop capability via SMS messaging
- 3 configurable maintenance alarms
- Compatible with a wide range of CAN engines, including tier 4 engine support
- Uses DSE Configuration Suite PC Software for simplified configuration
- Licence-free PC software
- IP65 rating (with supplied gasket) offers increased resistance to water ingress
- Modules can be integrated into building management systems (BMS) using MODBUS RTU

KEY BENEFITS

- Automatically transfers between mains (utility) and generator (DSE7320 MKII only) for convenience.
- Hours counter provides accurate information for monitoring and maintenance periods
- User-friendly set-up and button layout for ease of use
- Multiple parameters are monitored & displayed simultaneously for full visibility
- The module can be configured to suit a wide range of applications for user flexibility
- PLC editor allows user configurable functions to meet user specific application requirements.

SPECIFICATIONS

DC SUPPLY

CONTINUOUS VOLTAGE RATING
8 V to 35 V Continuous
5 V for upto 1 minute

CRANKING DROPOUTS

Able to survive 0 V for 100 ms, providing supply was at least 10 V before dropout and supply recovers to 5 V. This is achieved without the need for internal batteries. LEDs and backlight will not be maintained during cranking.

MAXIMUM OPERATING CURRENT

510 mA at 12 V, 240 mA at 24 V

MAXIMUM STANDBY CURRENT

330 mA at 12 V, 160 mA at 24 V

CHARGE FAIL/EXCITATION RANGE

0 V to 35 V

GENERATOR & MAINS (UTILITY) VOLTAGE RANGE

15 V to 415 V AC (Ph to N)
26 V to 719 V AC (Ph to Ph)

FREQUENCY RANGE

3.5 Hz to 75 Hz

MAGNETIC PICKUP

VOLTAGE RANGE
+/- 0.5 V to 70 V

FREQUENCY RANGE

10,000 Hz (max)

INPUTS

DIGITAL INPUTS A TO H
Negative switching

ANALOGUE INPUTS A & F

Configurable as:
Negative switching digital input
0 V to 10 V sensor
4 mA to 20 mA sensor
Resistive sensor

ANALOGUE INPUTS B, C, D & E

Configurable as:
Negative switching digital input
Resistive sensor

OUTPUTS

OUTPUT A & B (FUEL & START)
15 A DC at supply voltage

OUTPUTS C & D

8 A AC at 250 V AC (Volt-free)

AUXILIARY OUTPUTS E, F, G, H, I & J

2 A DC at supply voltage

DIMENSIONS

OVERALL
245 mm x 184 mm x 51 mm
9.6" x 7.2" x 2.0"

PANEL CUT-OUT

220 mm x 160 mm
8.7" x 6.3"

MAXIMUM PANEL THICKNESS

8 mm
0.3"

STORAGE TEMPERATURE RANGE

-40°C to +85°C
-40 °F to +185 °F

OPERATING TEMPERATURE RANGE

-30°C to +70°C
-22 °F to +158 °F

HEATED DISPLAY VARIANT

-40 °C to +70 °C
-40 °F to +158 °F

RELATED MATERIALS

TITLE

DSE7310 MKII & DSE7320 MKII Installation Instructions
DSE7310 MKII & DSE7320 MKII Operator Manual
DSE7310 MKII & DSE7320 MKII Configuration Suite PC Manual

PART NO.

053-181
057-253
057-243

DEEP SEA ELECTRONICS LTD

Highfield House, Hunmanby Industrial Estate, Hunmanby YO14 0PH
TELEPHONE +44 (0) 1723 890099
EMAIL sales@deepseaelectronics.com **WEBSITE** www.deepseaelectronics.com

DEEP SEA ELECTRONICS INC USA

3230 Williams Avenue, Rockford, IL 61101-2668 USA
TELEPHONE +1 (815) 316 8706
EMAIL usasales@deepseaelectronics.com **WEBSITE** www.deepseaelectronics.com

DSE7310/20 MKII

AUTO START & AUTO MAINS FAILURE CONTROL MODULES

The DSE7310 MKII is an Auto Start Control Module and the DSE7320 MKII is an Auto Mains (Utility) Failure Control Module suitable for a wide variety of single, diesel or gas, gen-set applications.

Monitoring an extensive number of engine parameters, the modules will display warnings, shutdown and engine status information on the back-lit LCD screen, illuminated LEDs, remote PC and via SMS text alerts (with external modem).

The DSE7320 MKII will also monitor the mains (utility) supply. The modules include USB, RS232 and RS485 ports as well as dedicated DSENet® terminals for system expansion.

Both modules are compatible with electronic (CAN) and non-electronic (magnetic pick-up/alternator sensing) engines and offer an extensive number of flexible inputs, outputs and extensive engine protections so the system can be easily adapted to meet the most demanding industry requirements.

The extensive list of features includes enhanced event and performance monitoring, remote communications & PLC functionality. Dual mutual standby is now available on both the DSE7310 MKII & DSE7320 MKII using RS232 or RS485 communications. This provides for a simpler and more convenient installation with more advanced features such as true engine hours balancing.

The modules can be easily configured using the DSE Configuration Suite PC software. Selected front panel editing is also available.

ENVIRONMENTAL TESTING STANDARDS

ELECTRO-MAGNETIC COMPATIBILITY

BS EN 61000-6-2
EMC Generic Immunity Standard for the Industrial Environment
BS EN 61000-6-4
EMC Generic Emission Standard for the Industrial Environment

ELECTRICAL SAFETY

BS EN 60950
Safety of Information Technology Equipment, including Electrical Business Equipment

TEMPERATURE

BS EN 60068-2-1
Ab/Ae Cold Test -30 °C
BS EN 60068-2-2
Bb/Be Dry Heat +70 °C

VIBRATION

BS EN 60068-2-6
Ten sweeps in each of three major axes
5 Hz to 8 Hz at +/-7.5 mm,
8 Hz to 500 Hz at 2 gn

HUMIDITY

BS EN 60068-2-30
Db Damp Heat Cyclic 20/55 °C at 95% RH 48 Hours
BS EN 60068-2-78
Cab Damp Heat Static 40 °C at 93% RH 48 Hours

SHOCK

BS EN 60068-2-27
Three shocks in each of three major axes
15 gn in 11 ms

DEGREES OF PROTECTION PROVIDED BY ENCLOSURES

BS EN 60529
IP65 - Front of module when installed into the control panel with the supplied sealing gasket.

COMPREHENSIVE FEATURE LIST TO SUIT A WIDE VARIETY OF GEN-SET APPLICATIONS

