

15KW Yanmar Compact Diesel Generator

Yanmar Engine | 60 Hz | 1800 RPM



Genset Specifications

Power	15 kW 20 kVA
Frequency	60 Hz
Speed	1800 RPM
Voltage	Any voltage can be customized
Phase	Single phase and Three phase options available
Overall Dimensions (L x W x H)	53.54 x 32.28 x 37.01 (in.)
Net Weight (lbs.)	770

Engine Data

Model	Yanmar 4TNV88-GGE
Cylinders	4 cylinder
Engine Speed	1800 RPM
Combustion Type	Direct Injection
Governor Type	Mechanical
Aspiration	Naturally Aspirated
Displacement (L)	2.19 L
Bore x Stroke (in.)	3.46 x 3.54 in.
Electrical System	12V-40A
Cooling Method	Water Pump

Alternator Data

Model	Stamford SOL2-G1
Excitation Mode	Self-exciting
Voltage Control Mode	AVR automatically regulates pressure
Type	Synchronous, brushless
Insulation Class	H
Protection Level	IP23



4TNV88-BGGES

4TNV88-BGGES-PPG

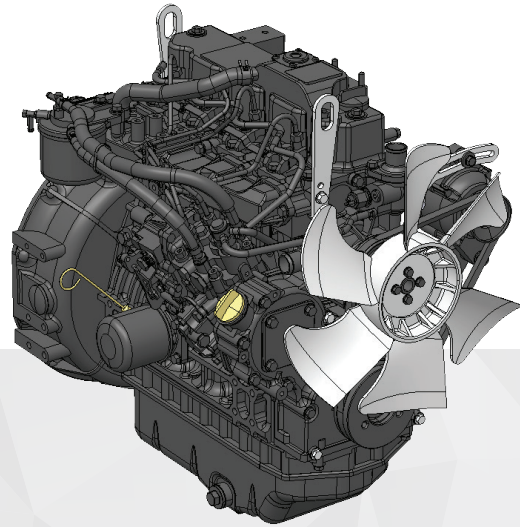

4TNV88-BGGES

LENGTH w/fan in (mm)	27.2 (691.5)	HEIGHT in (mm)	26.1 (662)
WIDTH in (mm)	20.5 (521)	WEIGHT (DRY) lbs (kg)	386 (175)

TYPICAL GENERATOR OUTPUT kWe (Standby)	19.8
TYPICAL GENERATOR OUTPUT KWE (PRIME)	18
CONTINUOUS GROSS ENGINE POWER hp (kW)	27.4 (20.5)
FUEL CONSUMPTION gal/h (l/h)	1.75 (6.61)
REGULATION	EPA Emergency Stationary
CYLINDERS	4
BORE X STROKE (mm)	88 x 90
DISPLACEMENT L (ci)	2.19 (134)
RATED SPEED rpm	1800
COMBUSTION TYPE	Direct Injection
ASPIRATION	Naturally Aspirated
GOVERNOR TYPE	Mechanical
LUBRICATION SYSTEM	7.4L Capacity Oil Pan
ELECTRICAL SYSTEM	12V-40A
FUEL SYSTEM	YPD-MP2 (Mechanical)
COOLING SYSTEM	Water Pump Belt Driven
POWER TAKE OFF	FWH:SAE 4 FW: SAE 7.5

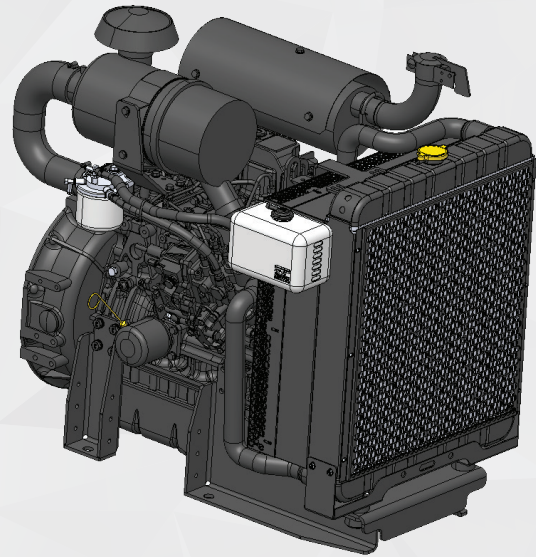

4TNV88-BGGES-PPG

LENGTH w/fan in (mm)	37.7 (957.4)	HEIGHT in (mm)	34.7 (881.4)
WIDTH in (mm)	26.7 (676.8)		



PURE. RELIABLE. POWER.

YANMAR is engaged in the relentless pursuit of high efficiency, low emission, diesel engines. With technology that already meets the next generation of environmental emissions standards, YANMAR is providing sustainable solutions towards a new era of prosperity.

www.yanmar.com
770.877.9894

©2022 YANMAR America Corporation. Engine photo may not reflect actual specifications. The information in this brochure is accurate as of the date of printing and subject to change. All rights reserved by and belong to YANMAR®.

1st. kW rating with fan loss included • 2nd. gal/h calculated from g/kWh using fuel weight of .82 and gross rated output
3rd. Generator kW rating based on generator efficiency of 92%, at sea level. • 4th. States & local areas may have additional requirements for emergency stationary engines. Not permitted for use in California.

STAMFORD®

S0L2-G1 Winding 14

S0L2-G1 - Technical Data Sheet

Standards

Stamford industrial alternators meet the requirements of IEC EN 60034 and the relevant section of other international standards such as BS5000, VDE 0530, NEMA MG1-32, IEC34, CSA C22.2-100 and AS1359. Other standards and certifications can be considered on request.

Quality Assurance

Alternators are manufactured using production procedures having a quality assurance level to BS EN ISO 9001.



Excitation and Voltage Regulators

Excitation System	
AVR Type	AVR Power
AS540	Self-Excited
Voltage Regulation	± 1%
No Load Excitation Voltage (V)	12.3 V
Full Load Excitation Voltage (V)	49.0 V

STAMFORD®

S0L2-G1 Winding 14

Electrical Data				
Insulation System	Class H			
Stator Winding	Double Layer Concentric			
Winding Pitch	Two Thirds			
Winding Leads	12			
Winding Number	14			
Number of Poles	4			
IP Rating	IP23			
RFI Suppression	EN 61000-6-2 & EN 61000-6-4, refer to factory for others			
Waveform Distortion	NO LOAD < 2.5% NON-DISTORTING BALANCED LINEAR LOAD < 5.0%			
Short Circuit Ratio	1/Xd			
Steady State X/R Ratio	N/A			
60 Hz				
Telephone Interference	TIF<75			
Voltage Series Star	380	400	416	-
Voltage Parallel Star	190	200	208	-
Voltage Series Delta	220	230	240	-
kVA Base Rating (Class H)	25	25	25	-
Saturated Values in Per Unit at Base Ratings and Voltages				
Xd Dir. Axis Synchronous	1.605	1.448	1.339	-
X'd Dir. Axis Transient	0.158	0.143	0.132	-
X''d Dir. Axis Subtransient	0.133	0.120	0.111	-
Xq Quad. Axis Reactance	1.498	1.352	1.250	-
X''q Quad. Axis Subtransient	0.165	0.149	0.138	-
XL Stator Leakage Reactance	0.087	0.079	0.073	-
X2 Negative Sequence Reactance	0.250	0.226	0.209	-
X0 Zero Sequence Reactance	0.050	0.045	0.042	-
Unsaturated Values in Per Unit at Base Ratings and Voltages				
Xd Dir. Axis Synchronous	1.926	1.738	1.607	-
X'd Dir. Axis Transient	0.182	0.164	0.152	-
X''d Dir. Axis Subtransient	0.156	0.140	0.130	-
Xq Quad. Axis Reactance	1.543	1.393	1.288	-
X''q Quad. Axis Subtransient	0.198	0.179	0.166	-
XL Stator Leakage Reactance	0.099	0.089	0.082	-
X2 Negative Sequence Reactance	0.301	0.271	0.251	-
X0 Zero Sequence Reactance	0.059	0.053	0.049	-
Time Constants (Seconds)				
T'd TRANSIENT TIME CONST.	0.019			
T''d SUB-TRANSTIME CONST.	0.002			
T'do O.C. FIELD TIME CONST.	0.51			
Ta ARMATURE TIME CONST.	0.005			

STAMFORD®

S0L2-G1 Winding 14

Resistances in Ohms (Ω) at 22°C	
Stator Winding Resistance (Ra)	0.272 Ω per phase series star connected
Rotor Winding Resistance (Rf)	0.644 Ω
Exciter Stator Winding Resistance	14.624 Ω
Exciter Rotor Winding Resistance	0.135 Ω per phase
Positive Sequence Resistance (R1)	0.34 Ω
Negative Sequence Resistance (R2)	0.392 Ω
Zero Sequence Resistance (R0)	0.34 Ω
Aux Winding Resistance	N/A
Mechanical data	
Cooling Air	0.126 m ³ /sec
Shaft and Keys	All alternator rotors are dynamically balanced to better than BS6861: Part 1 Grade 2.5 for minimum vibration in operation.
Bearing	Single Bearing
Weight Complete Alternator	106.5 kg
Weight Wound Stator	42.3 kg
Weight Wound Rotor	36.8 kg
Moment of Inertia	0.127 kgm ²
Shipping weight in a Crate	145 kg
Packing Crate Size	930X590X760 mm
Maximum Over Speed	2250 RPM for two minutes
Bearing Drive End	N/A
Bearing Non-Drive End	Ball Bearing, 6305-2RS1

STAMFORD®

S0L2-G1 Winding 14

RATINGS AT 0.8 POWER FACTOR

Class - Temp Rise	Standby - 163/27°C	Standby - 150/40°C	Cont. H - 125/40°C	Cont. F - 105/40°C
50 Hz	Series Star (V)			
	Parallel Star (V)	N/A	N/A	N/A
	Series Delta (V)			
	kVA			
	kW	N/A	N/A	N/A
	Efficiency (%)			
	kW Input			

60 Hz	Series Star (V)	380	400	416	-	380	400	416	-	380	400	416	-	380	400	416	-	
	Parallel Star (V)	190	200	208	-	190	200	208	-	190	200	208	-	190	200	208	-	
	Series Delta (V)	220	230	240	-	220	230	240	-	220	230	240	-	220	230	240	-	
		kVA	27.3	27.3	27.3	-	26.3	26.3	26.3	-	25.0	25.0	25.0	-	22.5	22.5	22.5	-
		kW	21.8	21.8	21.8	-	21.0	21.0	21.0	-	20.0	20.0	20.0	-	18.0	18.0	18.0	-
		Efficiency (%)	85.0	85.3	85.5	-	85.6	85.8	86.0	-	86.2	86.5	86.6	-	87.3	87.5	87.5	-
		kW Input	25.7	25.6	25.5	-	24.6	24.5	24.5	-	23.2	23.1	23.1	-	20.6	20.6	20.6	-

De-Rates

All values tabulated above are subject to the following reductions:

- 3% for every 500 meters by which the operating altitude exceeds 1000 meters above mean sea level
- 3% for every 5°C by which the operational ambient temperature exceeds 40°C
- For any other operating conditions impacting the cooling circuit please refer to applications

Note: Requirement for operating in an ambient exceeding 60°C and altitude exceeding 4000 meters must be referred to applications.

Dimensional and Torsional Drawing

For dimensional and torsional information please refer to the alternator General Arrangement and rotor drawings available on our website (<http://stamford-avk.com/>)

Note: Continuous development of our products means that the information contained in our data sheets can change without notice, and specifications should always be confirmed with Cummins Generator Technologies prior to purchase.

DSE6110/20 MKIII

AUTO START & AUTO MAINS (UTILITY) FAILURE CONTROL MODULES



DSE6110 MKIII



DSE6120 MKIII

KEY FEATURES

- 4-line back-lit LCD text display
- Multiple display languages
- Five-key menu navigation
- LCD alarm indication
- Customisable power-up text and screen images.
- DSENet® expansion compatibility
- Data logging facility
- Internal PLC editor
- Protections disable feature
- Fully configurable via PC using USB communications
- Front panel configuration with PIN protection
- Power save mode
- 3-phase generator sensing and protection
- 3-phase mains (utility) sensing and protection (DSE6120 MKIII only)
- Automatic load transfer control (DSE6120 MKIII only)
- Generator current and power monitoring (kW, kvar, kVA, pf)
- Mains (utility) current and power monitoring (kW, kvar, kVA, pf) (DSE6120 MKIII only)
- kW overload alarm
- Over current protection
- Breaker control via fascia buttons
- Fuel and start outputs configurable when using CAN
- 6 configurable DC outputs
- 4 configurable analogue/digital inputs
- Support for 0 V to 10 V & 4 mA to 20 mA sensors
- 8 configurable digital inputs
- CAN, MPU and alternator frequency speed sensing in one variant
- Real time clock
- Manual and automatic fuel pump control
- Engine pre-heat and post-heat functions
- Engine run-time scheduler
- Engine idle control for starting & stopping
- Fuel level alarms
- 3 configurable maintenance alarms
- Compatible with a wide range of CAN engines, including Tier 4 engine support
- Uses DSE Configuration Suite PC Software for simplified configuration
- Licence-free PC software
- IP65 rating (with optional gasket) offers increased resistance to water ingress
- Configurable CAN read & transmitted information.
- 1 alternative configuration.

KEY BENEFITS

- Automatically transfers between mains (utility) and generator (DSE6120 MKIII only) for convenience.
- Hours counter provides accurate information for monitoring and maintenance periods
- User-friendly set-up and button layout for ease of use
- Multiple parameters are monitored & displayed simultaneously for full visibility
- The module can be configured to suit a wide range of applications for user flexibility
- PLC editor allows user configurable functions to meet user specific application requirements.

SPECIFICATIONS

DC SUPPLY

CONTINUOUS VOLTAGE RATING
8 V to 35 V Continuous
5 V for up to 1 minute

CRANKING DROPOUTS

Able to survive 0 V for 100 mS, providing supply was at least 10 V before dropout and supply recovers to 5 V. This is achieved without the need for internal batteries. LEDs and backlight will not be maintained during cranking.

MAXIMUM OPERATING CURRENT

260 mA at 12 V, 150 mA at 24 V

MAXIMUM STANDBY CURRENT

145 mA at 12 V, 85 mA at 24 V

CHARGE FAIL/EXCITATION RANGE

0 V to 35 V

GENERATOR & MAINS (UTILITY)

VOLTAGE RANGE
15 V to 415 V AC (Ph to N)
26 V to 719 V AC (Ph to Ph)

FREQUENCY RANGE

3.5 Hz to 75 Hz

MAGNETIC PICKUP

VOLTAGE RANGE
+/- 0.5 V to 70 V

FREQUENCY RANGE

10,000 Hz (max)

INPUTS

DIGITAL INPUTS A TO H
Negative switching

ANALOGUE INPUTS A & D

Configurable as:
Negative switching digital input
0 V to 10 V sensor
4 mA to 20 mA sensor
Resistive sensor

ANALOGUE INPUTS B & C

Configurable as:
Negative switching digital input
Resistive sensor

OUTPUTS

OUTPUT A & B (FUEL & START)
10 A DC at supply voltage

AUXILIARY OUTPUTS C, D, E, F, G & H
2 A DC at supply voltage

DIMENSIONS

OVERALL
216 mm x 158 mm x 43 mm
8.5" x 6.2" x 1.5"

PANEL CUT-OUT

184 mm x 137 mm
7.2" x 5.3"

MAXIMUM PANEL THICKNESS

8 mm
0.3"

STORAGE TEMPERATURE RANGE

-40°C to +85°C
-40 °F to +185 °F

OPERATING TEMPERATURE RANGE

NON-HEATED DISPLAY VARIANT
-30°C to +70°C
-22 °F to +158 °F

HEATED DISPLAY VARIANT

-40 °C to +70 °C
-40 °F to +158 °F

OPTIONAL PARTS

PART	PART NUMBER
IP65 Gasket	020-521

RELATED MATERIALS

TITLE	PART NO.
DSE6110 MKIII & DSE6120 MKIII Installation Instructions	053-240
DSE6110 MKIII & DSE6120 MKIII Operator Manual	057-289
DSE6110 MKIII & DSE6120 MKIII Configuration Suite PC Manual	057-290

DEEP SEA ELECTRONICS

Highfield House, Hunmanby Industrial Estate, Hunmanby YO14 0PH
TELEPHONE +44 (0) 1723 890099 **FACSIMILE** +44 (0) 1723 893303
EMAIL sales@deepseapl.com **WEBSITE** www.deepseapl.com

DEEP SEA ELECTRONICS INC USA

3230 Williams Avenue, Rockford, IL 61101-2668 USA
TELEPHONE +1 (815) 316 8706 **FACSIMILE** +1 (815) 316 8708
EMAIL sales@deepseausa.com **WEBSITE** www.deepseausa.com

DSE6110/20 MKIII

AUTO START & AUTO MAINS (UTILITY) FAILURE CONTROL MODULES

The DSE6110 MKIII is an Auto Start Control Module and the DSE6120 MKIII is an Auto Mains (Utility) Failure Control Module suitable for a wide variety of single, diesel or gas, gen-set applications.

Monitoring an extensive number of engine parameters, the modules will display warnings, shutdown and engine status information on the back-lit LCD screen, illuminated LEDs and remote PC.

The DSE6120 MKIII will also monitor the mains (utility) supply. The modules include USB connection and dedicated DSENet® terminals for system expansion.

Both modules are compatible with electronic (CAN) and non-electronic (magnetic pick-up/alternator sensing) engines and offer an extensive number of flexible inputs, outputs and extensive engine protections so the system can be easily adapted to meet the most demanding industry requirements.

The extensive list of features includes enhanced event and performance monitoring, remote communications & PLC functionality.

The modules can be easily configured using the DSE Configuration Suite PC software. Selected front panel editing is also available.

ENVIRONMENTAL TESTING STANDARDS

ELECTRO-MAGNETIC COMPATIBILITY

BS EN 61000-6-2
EMC Generic Immunity Standard for the Industrial Environment
BS EN 61000-6-4
EMC Generic Emission Standard for the Industrial Environment

ELECTRICAL SAFETY

BS EN 60950
Safety of Information Technology Equipment, including Electrical Business Equipment

TEMPERATURE

BS EN 60068-2-1
Ab/Ae Cold Test -30 °C
BS EN 60068-2-2
Bb/Be Dry Heat +70 °C

VIBRATION

BS EN 60068-2-6
Ten sweeps in each of three major axes
5 Hz to 8 Hz at +/-7.5 mm,
8 Hz to 500 Hz at 2 gn

HUMIDITY

BS EN 60068-2-30
Db Damp Heat Cyclic 20/55 °C
at 95% RH 48 Hours
BS EN 60068-2-78
Cab Damp Heat Static 40 °C
at 93% RH 48 Hours

SHOCK

BS EN 60068-2-27
Three shocks in each of three major axes
15 gn in 11 ms

DEGREES OF PROTECTION PROVIDED BY ENCLOSURES

BS EN 60529
IP65 - Front of module when installed into the control panel with the optional sealing gasket.

COMPREHENSIVE FEATURE LIST TO SUIT A WIDE VARIETY OF GEN-SET APPLICATIONS

