

# 350KW Cummins Diesel Generator

1800RPM | 60 Hz | Cummins Engine

## General

Model	WDG-350-CMS
Fuel Type	Diesel
Standby Rating	350 KW / 438 KVA
Prime Rating	320 KW / 400 KVA
Frequency	60 Hz
Voltage	Any voltage can be customized
Phase	Single Phase or Three Phase
Enclosure Type	Silent, Weatherproof
Engine Brand	Cummins
Alternator Brand	Stamford
Controller Model	Deep Sea DSE 7310/7320



## Engine Data

Engine Model	Cummins QSG12-G3
Configuration	6 cylinder
Aspiration	Turbocharged, Air Cooled
Gross Engine Power Output	414 kWm
Bore x Stroke (in.)	5.20 x 5.67 (in.)
Rated Speed (RPM)	1800
Displacement (L)	12
Compression Ratio	17.0:1
Cooling Method	Radiator Cooled
Governor	Electronic

## Alternator Data

Alternator Model	Stamford HCI434E/444E
Type	Self-excited, Brushless
Power Factor	0.8
Voltage Regulation	AVR
Insulation System	Class H
Protection Level	IP23

## Size & Dimensions

Dimensions (L x W x H)	157 x 66.9 x 78.7 (in.)
Net Weight (lbs.)	6000

## Fuel Consumption

	Standby				Prime			
<b>Ratings</b>	350 KW   435 KVA				320 KW   400 KVA			
<b>Load</b>	<b>25%</b>	<b>50%</b>	<b>75%</b>	<b>100%</b>	<b>25%</b>	<b>50%</b>	<b>75%</b>	<b>100%</b>
<b>US gph</b>	6.7	12.2	18.0	24.6	6.3	11.4	16.4	22.5
<b>L/h</b>	25.5	46.0	68.0	93.0	24.0	43.0	62.0	85.0

## Generator set data sheet



**Model:** C350D6B  
**Frequency:** 60 Hz  
**Fuel type:** Diesel  
**kW rating:** 350 Standby  
 320 Prime

Exhaust emission data sheet:	
Sound performance data sheet:	
Cooling performance data sheet:	
Genset outline:	A066B105 (Aberto) / A072U854 (Fechado)

Fuel consumption	Standby				Prime			
	kW (kVA)				kW (kVA)			
Ratings	350 (438)				320 (400)			
Load	25%	50%	75%	100%	25%	50%	75%	100%
US gph	6.7	12.2	18.0	24.6	6.3	11.4	16.4	22.5
L/h	25.5	46.0	68.0	93.0	24.0	43.0	62.0	85.0

Engine	Stanby rating	Prime rating
Engine manufacturer	Cummins	
Engine model	QSG12-G3	
Configuration - No. of cylinders	6	
Aspiration	Turbocharged, Charge Air Cooled	
Gross engine power output, kWm (bhp)	414 (555)	378 (507)
BMEP at set rated load, kPa (psi)	2338 (339)	2136 (310)
Bore, mm (in.)	132 (5,20)	
Stroke, mm (in.)	144 (5,67)	
Rated speed, rpm	1800	
Compression ratio	17,0:1	
Lube oil capacity, L (US gal)	34,1 (9)	
Overspeed limit, rpm	2100 ± 50	
Governor type	Electronic	
Starting Voltage	24	

## Fuel flow

Maximum fuel flow, L/hr (US gph)	182 (48)
Maximum fuel inlet restriction, kPa (in Hg)	40.64 (12)
Maximum fuel inlet temperature, °C (°F)	71 (160)
Maximum fuel return line restriction, kPa (in Hg)	50.8 (15)

Air	Standby rating	Prime rating
Combustion air, CFM (L/s)	953.5 (450)	925.95 (437)
Maximum air cleaner restriction, kPa (in H2O)	6.23 (25)	
Alternator cooling air, m³/min (cfm)	55.2 (1949)	

## Exhaust

Exhaust flow at set rated load, CFM (L/s)	2300 (1085)	2145 (1012)
Exhaust temperature, °C (°F)	507 (945)	473 (883)
Maximum back pressure, kPa (in H2O)	10.16 (40.83)	

## Standard set-mounted radiator cooling

Ambient design, °C (°F)	50 (122)	
Fan load, kWm (HP)	19 (25.46)	
Coolant capacity (with radiator), L (US gal)	34 (8.98)	
Cooling system air flow, m³/min (scfm)	504 (17690.4)	
Total heat rejection, MJ/min (Btu/min)	8.38 (7947)	7.72 (7314)
Maximum cooling air flow static restriction, kPa (in H2O)	0.12 (0.5)	

## Weights

Unit Open dry weight*, kgs	2924
Unit Open wet weight*, kgs	3003
Unit Enclosed dry weight*, kgs	4065
Unit enclosed wet weight*, kgs	4144

\*Note: Weights represent a set with standard features. See outline drawings for weights of other configurations.

## Alternator data

Voltage	Connection	Temp rise degrees C	Duty <sup>1</sup>	Winding No.	Frame Size
220	3Phase	150	S/P	311	S4L1DF
380	3Phase	150	S/P	13	S4L1SF
440	3Phase	150	S/P	311	S4L1DF
480	3Phase	150	S/P	311	S4L1DF

### Notes:

<sup>1</sup> Standby (S) and Prime (P).

## Derating factors

<b>Standby</b>	Rated power available up to 1158 m (3800 ft) elevation at an ambient temperature of 40°C (104°F). Above these conditions, it should be reduced by 1.5% every 500 m (1640 feet) up to 3048 m (10000 ft) and 6.3% for every 10 ° C (18 ° F). For other temperature and altitude limits, consult a Cummins distributor.
<b>Prime</b>	Rated power available up to 2194 m (7200 ft) elevation at an ambient temperature of 40°C (104°F). Above these conditions, it should be reduced by 2.2% every 500 m (1640 feet) up to 3048 m (10000 ft) and 6.1% for every 10 ° C (18 ° F). For other temperature and altitude limits, consult a Cummins distributor.

## Ratings definitions

<b>Emergency Standby Power (ESP):</b>	<b>Limited-Time Running Power (LTP):</b>	<b>Prime Power (PRP):</b>	<b>Base Load (Continuous) Power (COP):</b>
Applicable for supplying power to varying electrical load for the duration of power interruption of a reliable utility source. Emergency Standby Power (ESP) is in accordance with ISO 8528. Fuel stop power in accordance with ISO 3046, AS 2789, DIN 6271 and BS 5514.	Applicable for supplying power to a constant electrical load for limited hours. Limited-Time Running Power (LTP) is in accordance with ISO 8528.	Applicable for supplying power to varying electrical load for unlimited hours. Prime Power (PRP) is in accordance with ISO 8528. Ten percent overload capability is available in accordance with ISO 3046, AS 2789, DIN 6271 and BS 5514.	Applicable for supplying power continuously to a constant electrical load for unlimited hours. Continuous Power (COP) is in accordance with ISO 8528, ISO 3046, AS 2789, DIN 6271 and BS 5514.

## Formulas for calculating full load currents:

### Three phase output

$$\frac{\text{kW} \times 1000}{\text{Voltage} \times 1.73 \times 0.8}$$

Warning: Back feed to a utility system can cause electrocution and/or property damage. Do not connect to any building's electrical system except through an approved device or after building main switch is open.

**For more information contact your local Cummins distributor  
or visit [power.cummins.com](http://power.cummins.com)**



### **Our Energy working for you.™**

© 2025 Cummins Inc. All rights reserved. Cummins is a registered trademark of Cummins Inc. PowerCommand, AmpSentry, InPower and "Our energy working for you." are trademarks of Cummins Inc. Other company, product, or service names may be trademarks or service marks of others. Specifications are subject to change without notice.

# STAMFORD®

**HCI 434E/444E - Winding 311**

Technical Data Sheet

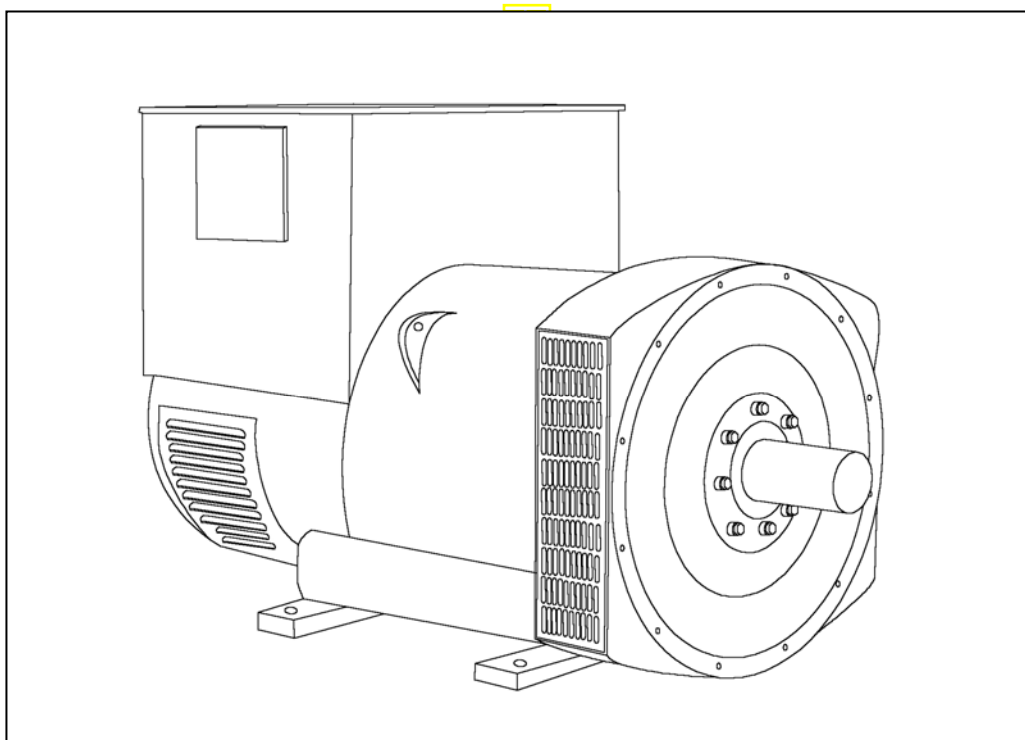

# HCI434E/444E

## SPECIFICATIONS & OPTIONS

**STAMFORD**

### STANDARDS

Stamford industrial generators meet the requirements of BS EN 60034 and the relevant section of other international standards such as BS5000, VDE 0530, NEMA MG1-32, IEC34, CSA C22.2 100, AS1359.

Other standards and certifications can be considered on request.

### VOLTAGE REGULATORS

#### AS440 AVR - STANDARD

With this self-excited system the main stator provides power via the Automatic Voltage Regulator (AVR) to the exciter stator. The high efficiency semi-conductors of the AVR ensure positive build-up from initial low levels of residual voltage.

The exciter rotor output is fed to the main rotor through a three-phase full-wave bridge rectifier. The rectifier is protected by a surge suppressor against surges caused, for example, by short circuit or out-of-phase paralleling.

The AS440 will support a range of electronic accessories, including a 'droop' Current Transformer (CT) to permit parallel operation with other ac generators.

#### MX341 AVR

This sophisticated AVR is incorporated into the Stamford Permanent Magnet Generator (PMG) control system.

The PMG provides power via the AVR to the main exciter, giving a source of constant excitation power independent of generator output. The main exciter output is then fed to the main rotor through a full wave bridge, protected by a surge suppressor. The AVR has in-built protection against sustained over-excitation, caused by internal or external faults. This de-excites the machine after a minimum of 5 seconds.

An engine relief load acceptance feature can enable full load to be applied to the generator in a single step.

If three-phase sensing is required with the PMG system the MX321 AVR must be used.

We recommend three-phase sensing for applications with greatly unbalanced or highly non-linear loads.

#### MX321 AVR

The most sophisticated of all our AVRs combines all the features of the MX341 with, additionally, three-phase rms sensing, for improved regulation and performance.

Over voltage protection is built-in and short circuit current level adjustments is an optional facility.

### WINDINGS & ELECTRICAL PERFORMANCE

All generator stators are wound to 2/3 pitch. This eliminates triplen (3rd, 9th, 15th ...) harmonics on the voltage waveform and is found to be the optimum design for trouble-free supply of non-linear loads. The 2/3 pitch design avoids excessive neutral currents sometimes seen with higher winding pitches, when in parallel with the mains. A fully connected damper winding reduces oscillations during paralleling. This winding, with the 2/3 pitch and carefully selected pole and tooth designs, ensures very low waveform distortion.

### TERMINALS & TERMINAL BOX

Standard generators are 3-phase reconnectable with 12 ends brought out to the terminals, which are mounted on a cover at the non-drive end of the generator. A sheet steel terminal box contains the AVR and provides ample space for the customers' wiring and gland arrangements. It has removable panels for easy access.

### SHAFT & KEYS

All generator rotors are dynamically balanced to better than BS6861:Part 1 Grade 2.5 for minimum vibration in operation. Two bearing generators are balanced with a half key.

### INSULATION/IMPREGNATION

The insulation system is class 'H'.

All wound components are impregnated with materials and processes designed specifically to provide the high build required for static windings and the high mechanical strength required for rotating components.

### QUALITY ASSURANCE

Generators are manufactured using production procedures having a quality assurance level to BS EN ISO 9001.

The stated voltage regulation may not be maintained in the presence of certain radio transmitted signals. Any change in performance will fall within the limits of Criteria 'B' of EN 61000-6-2:2001. At no time will the steady-state voltage regulation exceed 2%.

### DE RATES

All values tabulated on page 8 are subject to the following reductions

5% when air inlet filters are fitted.

3% for every 500 metres by which the operating altitude exceeds 1000 metres above mean sea level.

3% for every 5°C by which the operational ambient temperature exceeds 40°C.

Note: Requirement for operating in an ambient exceeding 60°C must be referred to the factory.

*NB Continuous development of our products entitles us to change specification details without notice, therefore they must not be regarded as binding.*

*Front cover drawing typical of product range.*

# HCI434E/444E



## WINDING 311

CONTROL SYSTEM	SEPARATELY EXCITED BY P.M.G.							
A.V.R.	MX321	MX341						
VOLTAGE REGULATION	± 0.5 %	± 1.0 %	With 4% ENGINE GOVERNING					
SUSTAINED SHORT CIRCUIT	REFER TO SHORT CIRCUIT DECREMENT CURVES (page 7)							
CONTROL SYSTEM	SELF EXCITED							
A.V.R.	AS440							
VOLTAGE REGULATION	± 1.0 %	With 4% ENGINE GOVERNING						
SUSTAINED SHORT CIRCUIT	WILL NOT SUSTAIN A SHORT CIRCUIT							
INSULATION SYSTEM	CLASS H							
PROTECTION	IP23							
RATED POWER FACTOR	0.8							
STATOR WINDING	DOUBLE LAYER LAP							
WINDING PITCH	TWO THIRDS							
WINDING LEADS	12							
STATOR WDG. RESISTANCE	0.009 Ohms PER PHASE AT 22°C SERIES STAR CONNECTED							
ROTOR WDG. RESISTANCE	1.19 Ohms at 22°C							
EXCITER STATOR RESISTANCE	18 Ohms at 22°C							
EXCITER ROTOR RESISTANCE	0.068 Ohms PER PHASE AT 22°C							
R.F.I. SUPPRESSION	BS EN 61000-6-2 & BS EN 61000-6-4, VDE 0875G, VDE 0875N. refer to factory for others							
WAVEFORM DISTORTION	NO LOAD < 1.5% NON-DISTORTING BALANCED LINEAR LOAD < 5.0%							
MAXIMUM OVERSPEED	2250 Rev/Min							
BEARING DRIVE END	BALL. 6317 (ISO)							
BEARING NON-DRIVE END	BALL. 6314 (ISO)							
	1 BEARING				2 BEARING			
WEIGHT COMP. GENERATOR	1024 kg				1030 kg			
WEIGHT WOUND STATOR	470 kg				470 kg			
WEIGHT WOUND ROTOR	400 kg				377 kg			
WR <sup>2</sup> INERTIA	4.6331 kgm <sup>2</sup>				4.4343 kgm <sup>2</sup>			
SHIPPING WEIGHTS in a crate	1095 kg				1100 kg			
PACKING CRATE SIZE	155 x 87 x 107(cm)				155 x 87 x 107(cm)			
	50 Hz				60 Hz			
TELEPHONE INTERFERENCE	THF<2%				TIF<50			
COOLING AIR	0.8 m <sup>3</sup> /sec 1700 cfm				0.99 m <sup>3</sup> /sec 2100 cfm			
VOLTAGE SERIES STAR	380/220	400/231	415/240	440/254	416/240	440/254	460/266	480/277
VOLTAGE PARALLEL STAR	190/110	200/115	208/120	220/127	208/120	220/127	230/133	240/138
VOLTAGE SERIES DELTA	220/110	230/115	240/120	254/127	240/120	254/127	266/133	277/138
KVA BASE RATING FOR REACTANCE VALUES	350	350	350	350	400	420	440	440
X <sub>d</sub> DIR. AXIS SYNCHRONOUS	3.01	2.71	2.52	2.24	3.47	3.26	3.12	2.87
X' <sub>d</sub> DIR. AXIS TRANSIENT	0.20	0.18	0.17	0.15	0.21	0.20	0.19	0.17
X'' <sub>d</sub> DIR. AXIS SUBTRANSIENT	0.14	0.13	0.12	0.11	0.15	0.14	0.13	0.12
X <sub>q</sub> QUAD. AXIS REACTANCE	2.58	2.33	2.16	1.92	2.92	2.74	2.63	2.41
X'' <sub>q</sub> QUAD. AXIS SUBTRANSIENT	0.36	0.32	0.30	0.27	0.41	0.38	0.37	0.34
X <sub>L</sub> LEAKAGE REACTANCE	0.07	0.06	0.06	0.05	0.08	0.08	0.07	0.07
X <sub>2</sub> NEGATIVE SEQUENCE	0.24	0.22	0.20	0.18	0.28	0.26	0.25	0.23
X <sub>0</sub> ZERO SEQUENCE	0.10	0.09	0.08	0.07	0.10	0.09	0.09	0.08
REACTANCES ARE SATURATED				VALUES ARE PER UNIT AT RATING AND VOLTAGE INDICATED				
T' <sub>d</sub> TRANSIENT TIME CONST.	0.08s							
T'' <sub>d</sub> SUB-TRANSTIME CONST.	0.019s							
T' <sub>do</sub> O.C. FIELD TIME CONST.	1.7s							
T <sub>a</sub> ARMATURE TIME CONST.	0.018s							
SHORT CIRCUIT RATIO	1/X <sub>d</sub>							

**Three-phase Short Circuit Decrement Curve. No-load Excitation at Rated Speed  
Based on star (wye) connection.**

**50  
Hz**

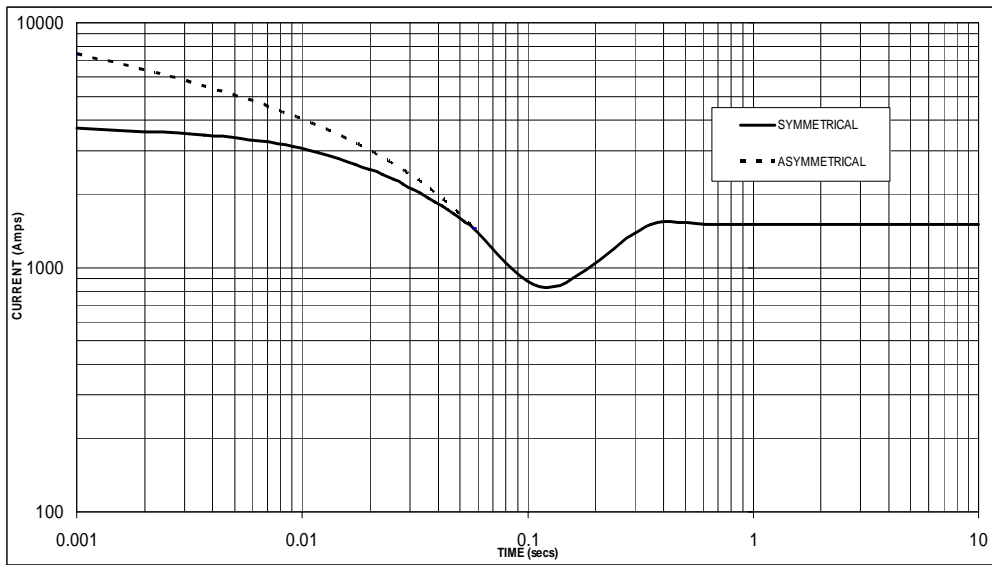

Sustained Short Circuit = 1,500 Amps

**60  
Hz**

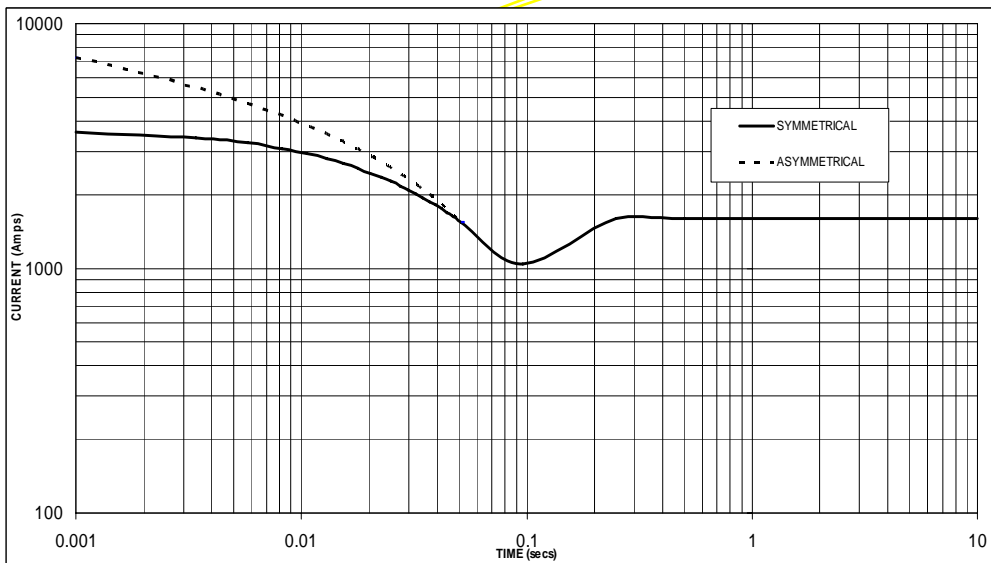

Sustained Short Circuit = 1,600 Amps

**Note 1**

The following multiplication factors should be used to adjust the values from curve between time 0.001 seconds and the minimum current point in respect of nominal operating voltage :

50Hz		60Hz	
Voltage	Factor	Voltage	Factor
380v	X 1.00	416v	X 1.00
400v	X 1.05	440v	X 1.06
415v	X 1.10	460v	X 1.10
440v	X 1.16	480v	X 1.15

The sustained current value is constant irrespective of voltage level

**Note 2**

The following multiplication factor should be used to convert the values calculated in accordance with NOTE 1 to those applicable to the various types of short circuit :

	3-phase	2-phase L-L	1-phase L-N
Instantaneous	x 1.00	x 0.87	x 1.30
Minimum	x 1.00	x 1.80	x 3.20
Sustained	x 1.00	x 1.50	x 2.50
Max. sustained duration	10 sec.	5 sec.	2 sec.

All other times are unchanged

**Note 3**

Curves are drawn for Star (Wye) connected machines. For other connection the following multipliers should be applied to current values as shown :

# HCI434E/444E

## Winding 311 / 0.8 Power Factor

**STAMFORD**

### RATINGS

Class - Temp Rise	Cont. F - 105/40°C				Cont. H - 125/40°C				Standby - 150/40°C				Standby - 163/27°C				
<b>50 Hz</b>	Series Star (V)	380	400	415	440	380	400	415	440	380	400	415	440	380	400	415	440
	Parallel Star (V)	190	200	208	220	190	200	208	220	190	200	208	220	190	200	208	220
	Series Delta (V)	220	230	240	254	220	230	240	254	220	230	240	254	220	230	240	254
kVA	320	320	320	320	350	350	350	350	370	370	370	370	380	400	380	380	
kW	256	256	256	256	280	280	280	280	296	296	296	296	304	320	304	304	
Efficiency (%)	93.6	93.8	94.0	94.1	93.2	93.5	93.6	93.8	92.9	93.2	93.4	93.6	92.7	92.7	93.2	93.5	
kW Input	274	273	272	272	300	299	299	299	319	318	317	316	328	345	326	325	

<b>60 Hz</b>	Series Star (V)	416	440	460	480	416	440	460	480	416	440	460	480	416	440	460	480
	Parallel Star (V)	208	220	230	240	208	220	230	240	208	220	230	240	208	220	230	240
	Series Delta (V)	240	254	266	277	240	254	266	277	240	254	266	277	240	254	266	277
kVA	365	385	400	400	400	420	440	440	420	445	460	460	435	455	475	475	
kW	292	308	320	320	320	336	352	352	336	356	368	368	348	364	380	380	
Efficiency (%)	93.8	93.8	93.9	94.0	93.4	93.5	93.5	93.7	93.1	93.2	93.2	93.5	92.9	93.0	93.1	93.3	
kW Input	311	328	341	340	343	359	376	376	361	382	395	394	375	391	408	407	

### DIMENSIONS

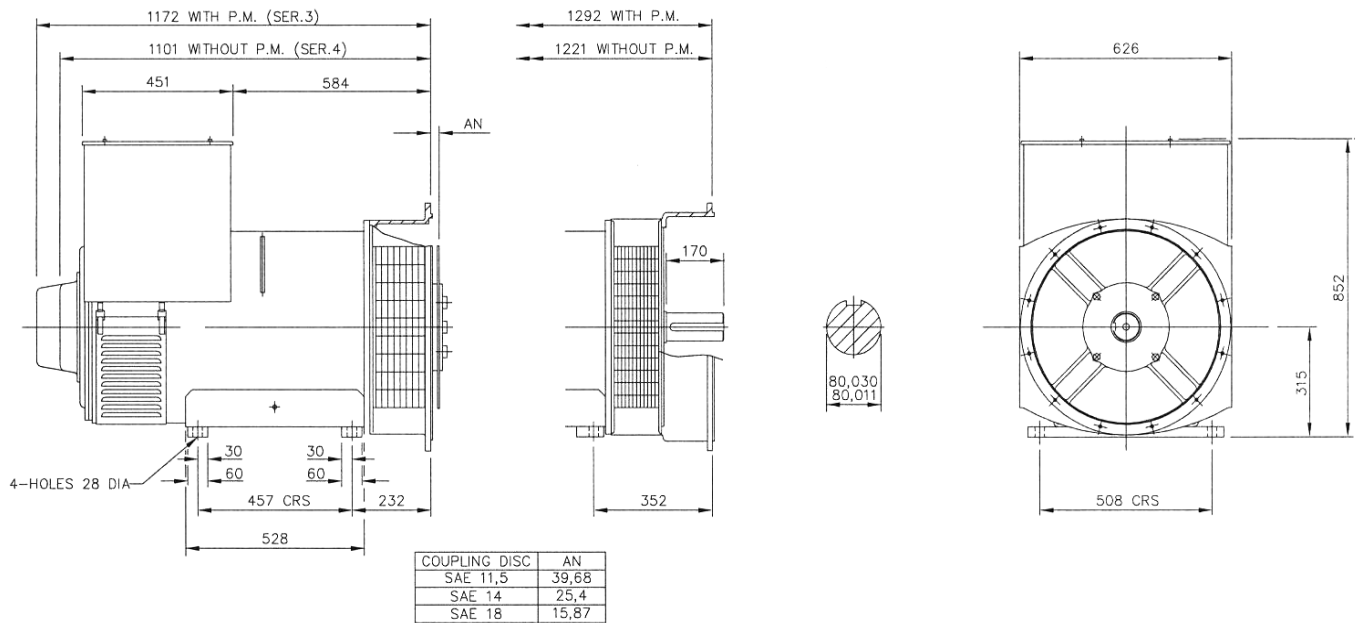

# DSE7310/20 MKII

## AUTO START & AUTO MAINS FAILURE CONTROL MODULES



### KEY FEATURES

- Configurable power-up mode
- MPU fail delay
- Enhanced graphical user interface
- Drag & drop advanced PLC editor
- MSC ID within PLC GenComm override
- 4-Line back-lit LCD text display
- Multiple Display Languages
- Five key menu navigation
- LCD alarm indication
- Heated display option available
- Customisable power-up text and images
- DSENet expansion compatibility
- Data logging facility
- Internal PLC editor
- Protections disable feature
- Fully configurable via PC using USB, RS232 & RS485 communication
- Front panel configuration with PIN protection
- Power save mode
- 3 phase generator sensing and protection
- 3 phase mains (utility) sensing and protection (DSE7320 MKII only)
- Automatic load transfer control (DSE7320 MKII only)
- Generator current and power monitoring (kW, kvar, kVA, pf)
- Mains current and power monitoring (kW, kvar, kVA, pf) (DSE7320 MKII only)
- kW and kvar overload and reverse power alarms
- Over current protection
- Unbalanced load protection
- Independent earth fault protection
- Breaker control via fascia buttons
- Fuel and start outputs configurable when using CAN
- 6 configurable DC outputs
- 2 configurable volt-free relay outputs
- 6 configurable analogue/digital inputs
- Support for 0 V to 10 V & 4 mA to 20 mA sensors
- 8 configurable digital inputs
- Configurable 5 stage dummy load and load shedding outputs
- CAN, MPU and alternator frequency speed sensing in one variant
- Real time clock
- Manual and automatic fuel pump control
- Engine pre-heat and post-heat functions
- Engine run-time scheduler
- Engine idle control for starting & stopping
- Fuel usage monitor and low fuel level alarms
- Simultaneous use of RS232 and RS485 communication ports
- True dual mutual standby using RS232 or RS485 for accurate engine hours balancing.
- MODBUS RTU support with configurable MODBUS pages.
- Advanced SMS messaging (additional external modem required)
- Start & stop capability via SMS messaging
- 3 configurable maintenance alarms
- Compatible with a wide range of CAN engines, including tier 4 engine support
- Uses DSE Configuration Suite PC Software for simplified configuration
- Licence-free PC software
- IP65 rating (with supplied gasket) offers increased resistance to water ingress
- Modules can be integrated into building management systems (BMS) using MODBUS RTU

### KEY BENEFITS

- Automatically transfers between mains (utility) and generator (DSE7320 MKII only) for convenience.
- Hours counter provides accurate information for monitoring and maintenance periods
- User-friendly set-up and button layout for ease of use
- Multiple parameters are monitored & displayed simultaneously for full visibility
- The module can be configured to suit a wide range of applications for user flexibility
- PLC editor allows user configurable functions to meet user specific application requirements.

### SPECIFICATIONS

#### DC SUPPLY

**CONTINUOUS VOLTAGE RATING**  
8 V to 35 V Continuous  
5 V for upto 1 minute

#### CRANKING DROPOUTS

Able to survive 0 V for 100 ms, providing supply was at least 10 V before dropout and supply recovers to 5 V. This is achieved without the need for internal batteries. LEDs and backlight will not be maintained during cranking.

#### MAXIMUM OPERATING CURRENT

510 mA at 12 V, 240 mA at 24 V

#### MAXIMUM STANDBY CURRENT

330 mA at 12 V, 160 mA at 24 V

#### CHARGE FAIL/EXCITATION RANGE

0 V to 35 V

#### GENERATOR & MAINS (UTILITY) VOLTAGE RANGE

15 V to 415 V AC (Ph to N)  
26 V to 719 V AC (Ph to Ph)

#### FREQUENCY RANGE

3.5 Hz to 75 Hz

#### MAGNETIC PICKUP VOLTAGE RANGE

+/- 0.5 V to 70 V

#### FREQUENCY RANGE

10,000 Hz (max)

#### INPUTS

**DIGITAL INPUTS A TO H**  
Negative switching

#### ANALOGUE INPUTS A & F

Configurable as:  
Negative switching digital input  
0 V to 10 V sensor  
4 mA to 20 mA sensor  
Resistive sensor

#### ANALOGUE INPUTS B, C, D & E

Configurable as:  
Negative switching digital input  
Resistive sensor

#### OUTPUTS

**OUTPUT A & B (FUEL & START)**  
15 A DC at supply voltage

#### OUTPUTS C & D

8 A AC at 250 V AC (Volt-free)

#### AUXILIARY OUTPUTS E, F, G, H, I & J

2 A DC at supply voltage

#### DIMENSIONS

**OVERALL**  
245 mm x 184 mm x 51 mm  
9.6" x 7.2" x 2.0"

#### PANEL CUT-OUT

220 mm x 160 mm  
8.7" x 6.3"

#### MAXIMUM PANEL THICKNESS

8 mm  
0.3"

#### STORAGE TEMPERATURE RANGE

-40°C to +85°C  
-40 °F to +185 °F

#### OPERATING TEMPERATURE RANGE

-30°C to +70°C  
-22 °F to +158 °F

#### HEATED DISPLAY VARIANT

-40 °C to +70 °C  
-40 °F to +158 °F

### RELATED MATERIALS

TITLE	PART NO.
DSE7310 MKII & DSE7320 MKII Installation Instructions	053-181
DSE7310 MKII & DSE7320 MKII Operator Manual	057-253
DSE7310 MKII & DSE7320 MKII Configuration Suite PC Manual	057-243

### DEEP SEA ELECTRONICS LTD

Highfield House, Hunmanby Industrial Estate, Hunmanby YO14 0PH  
**TELEPHONE** +44 (0) 1723 890099  
**EMAIL** sales@deepseaelectronics.com **WEBSITE** www.deepseaelectronics.com

### DEEP SEA ELECTRONICS INC USA

3230 Williams Avenue, Rockford, IL 61101-2668 USA  
**TELEPHONE** +1 (815) 316 8706  
**EMAIL** usasales@deepseaelectronics.com **WEBSITE** www.deepseaelectronics.com

# DSE7310/20 MKII

## AUTO START & AUTO MAINS FAILURE CONTROL MODULES

The DSE7310 MKII is an Auto Start Control Module and the DSE7320 MKII is an Auto Mains (Utility) Failure Control Module suitable for a wide variety of single, diesel or gas, gen-set applications.

Monitoring an extensive number of engine parameters, the modules will display warnings, shutdown and engine status information on the back-lit LCD screen, illuminated LEDs, remote PC and via SMS text alerts (with external modem).

The DSE7320 MKII will also monitor the mains (utility) supply. The modules include USB, RS232 and RS485 ports as well as dedicated DSENet® terminals for system expansion.

Both modules are compatible with electronic (CAN) and non-electronic (magnetic pick-up/alternator sensing) engines and offer an extensive number of flexible inputs, outputs and extensive engine protections so the system can be easily adapted to meet the most demanding industry requirements.

The extensive list of features includes enhanced event and performance monitoring, remote communications & PLC functionality. Dual mutual standby is now available on both the DSE7310 MKII & DSE7320 MKII using RS232 or RS485 communications. This provides for a simpler and more convenient installation with more advanced features such as true engine hours balancing.

The modules can be easily configured using the DSE Configuration Suite PC software. Selected front panel editing is also available.

### ENVIRONMENTAL TESTING STANDARDS

#### ELECTRO-MAGNETIC COMPATIBILITY

BS EN 61000-6-2  
EMC Generic Immunity Standard for the Industrial Environment  
BS EN 61000-6-4  
EMC Generic Emission Standard for the Industrial Environment

#### ELECTRICAL SAFETY

BS EN 60950  
Safety of Information Technology Equipment, including Electrical Business Equipment

#### TEMPERATURE

BS EN 60068-2-1  
Ab/Ae Cold Test -30 °C  
BS EN 60068-2-2  
Bb/Be Dry Heat +70 °C

#### VIBRATION

BS EN 60068-2-6  
Ten sweeps in each of three major axes  
5 Hz to 8 Hz at +/-7.5 mm,  
8 Hz to 500 Hz at 2 gn

#### HUMIDITY

BS EN 60068-2-30  
Db Damp Heat Cyclic 20/55 °C at 95% RH 48 Hours  
BS EN 60068-2-78  
Cab Damp Heat Static 40 °C at 93% RH 48 Hours

#### SHOCK

BS EN 60068-2-27  
Three shocks in each of three major axes  
15 gn in 11 ms

#### DEGREES OF PROTECTION PROVIDED BY ENCLOSURES

BS EN 60529  
IP65 - Front of module when installed into the control panel with the supplied sealing gasket.

## COMPREHENSIVE FEATURE LIST TO SUIT A WIDE VARIETY OF GEN-SET APPLICATIONS

